

DS-TDSB00-EKH/POE/2M 2 m Auxiliary Care Radar



Based on the 60 GHz frequency band, vital sign detection radar adopts FMCW, MIMO, beamforming, micro-Doppler feature extraction, and other technologies. It can detect the vital signs, including person, breath, heartbeat, etc. Vital sign detection radar can be installed above the bed in the bedroom, and the non-contact detection will cover the bed. It can obtain the information, including the time in the bed, the time out of the bed, breath rate, heart rate, times of movements, etc., and help to analyze the sleep quality and health of the human body.

- No privacy disclosure.
- Remote and non-contact detection.
- Outputs the real-time breath rate and heart rate of the human body.
- Detects and outputs the information that if the human body is in the bed to the connected client software. Counts the time in the bed and the time out of the bed.
- Detects and outputs the human body movements to the connected client software, and counts the times of movements.
- Supports truning off indicator.
- Supports transmitting data to platform by OTAP protocol.
- Supports connecting to Wi-Fi.
- Supports side mounting and cell mounting.

▪ Specification

General	
Working Humidity	95% or less (non-condensing)
Weight	Approx. 170 g (0.37 lb.)
Radar	
Working Frequency Range	60 GHz to 64 GHz
Modulation Waveform	FMCW
Capture Distance	0.1 m to 2.7 m
Communication Interface	1 RJ45 Ethernet interface, WIFI
Working Voltage	Type-C DC5V, IEEE 802.3af POE
Working Current	≤ 700 mA
Working Temperature	-10 °C to +50 °C (14 °F to +122 °F)

▪ Typical Application

Whether the human body is in the bed: The radar provides real-time detection of the human body in the bed. If there is a person in the bed, the connected client software will show the sign that someone is in the bed, otherwise it will show the sign that no one is in the bed.

Breath rate and heart rate: If there is someone in the bed, the radar will detect and output the real-time breath rate and heart rate (unit: times/minute) to the connected client software. If there is no one in the bed, the breath rate and heart rate will be 0.

Body movements: The radar will detect the real-time rolling over of the human body and count the times.

▪ Available Model

DS-TDSB00-EKH/POE/2m

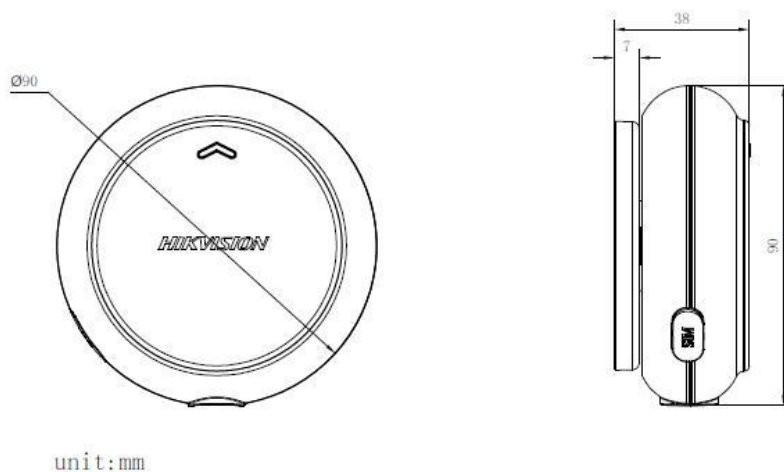
▪ Dimension**Headquarters**

No.555 Qianmo Road, Binjiang District,
Hangzhou 310051, China
T +86-571-8807-5998
www.hikvision.com

Follow us on social media to get the latest product and solution information.



Hikvision



HikvisionHQ



HikvisionHQ



Hikvision_Global

Hikvision
Corporate Channel

hikvisionhq

