

DC108R4.7

Contacto magnético gran potencia de suelo. Apertura operativa máx. 75mm. 2m de cable blindado. EOL 4K7.

Overhead door magnetic contact

The DC108 series overhead door magnetic contact is for use in the rigorous environments of commercial and industrial installations. The floor mount units are constructed with a low profile heavy cast aluminium housing. The reed switch assembly is fully encased in an exclusive polyurethane potting material to prevent damage due to moisture or humidity.

Easy installation

A wide operating gap distance of up to 7.5 cm makes installation easy and helps prevent false alarms caused by door movement or damaged and loose fitting doors.



Details

- Miniature, low-profile design
- Stainless steel armoured cable for added security, reliability
- Wide working gap for overhead doors
- Small size less likely to be damaged by forklifts
- Tamper loop provided

DC108R4.7

Contacto magnético gran potencia de suelo. Apertura operativa máx. 75mm. 2m de cable blindado. EOL 4K7.

Technical specifications

General

Tipo de Aplicación	Montaje en Superficie
Tipo de contacto	Resistencia 4K7
Conectividad	4 wires, 2 m (armoured cable)

Wired/wireless

Wired-wireless	Cableado
----------------	----------

Physical

Material	Aluminio
Dimensiones del imán	89 x 39 x 39 mm
Dimensiones del contacto / sensor	89 x 39 x 39 mm
Brecha de funcionamiento	75 mm (max.)

Standards & regulation

Grado EN50131	Grado 2
---------------	---------

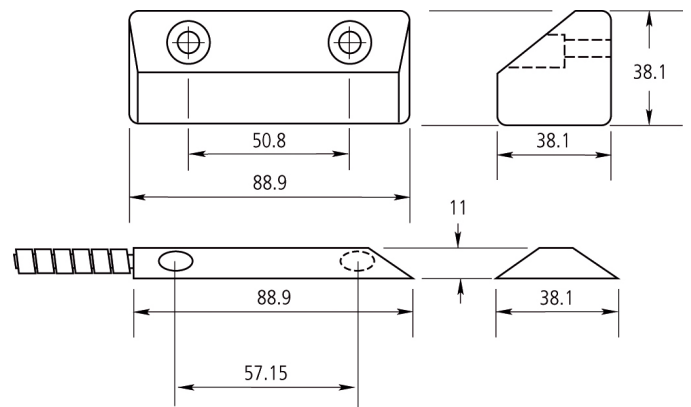

Como empresa innovadora, Carrier Fire & Security se reserva el derecho de modificar las especificaciones de los productos sin previo aviso. Para conocer las últimas especificaciones de los productos, visite la Web de es.firesecurityproducts.com o póngase en contacto con su comercial.

Last updated on 23 July 2021 - 9:53